

RAY

COMPACT ENERGY METER | MECHANICAL

DIEHL
Metering



APPLICATION

Fully electronic compact heat meter or compact cooling and heat meter with impeller scanning for recording energy and volume data. Highly accurate recording of all billing data in a heating circuit or a cooling / heating circuit at medium temperatures from 5 °C up to 90 °C.

FEATURES

- ▶ Electronic sensor control for recording flow rate
- ▶ Lithium battery, lifetime up to 12 years
- ▶ Optical ZVEI interface equipped as standard
- ▶ Adjustable reading date for billing
- ▶ Rotatable integrator
- ▶ Single-line 7-digit display for easy meter reading

COMPONENTS

- Volume measuring component (DN 15 - 100)
- Calculator, contains hardware and software for measuring flow rate, temperature and energy consumption
- Temperature sensor permanently connected in integrator

CALCULATOR - BASIC FEATURES

RAY	
Ambient class	EN 1434 class C / MID E1 + M1
Protection class DIN 40050 / IEC-EN 60529	IP 54 (heat meter) IP 65 with potted calculator (combined heat-cooling / cooling meter)
Interfaces standard	Optical ZVEI according IEC 870-5
Interfaces optional	M-Bus, radio, pulse

Note: IZAR@SET / HYDRO-SET Software for configuration of meters, readout of measured values and printout of meter logs. Available under www.diehl.com/metering (Products - downloads)

DISPLAY

RAY	
Display indication	LCD, 7-digit
Unit	MWh - kWh - GJ - MJ - kW - m ³ /h - l/h - m ³ - l
Total values	9,999,999 - 999,999.9 - 99,999.99 - 9,999.999
Values displayed	Power - energy - flow rate - temperature - energy on reading date - reading date

TEMPERATURE INPUT

RAY			
Temperature sensor type	Pt 500 / 2-wire		
Measuring cycle	T	s	32
Max. temperature difference	$\Delta\theta$	K	+147
Min. temperature difference	$\Delta\theta$	K	+3
Starting temperature difference	$\Delta\theta$	K	+0.25
Absolute temperature measurement range	θ	°C	0 ... 150

SUPPLY VOLTAGE

RAY			
Operating voltage	U_N	V_{DC}	3.0 (lithium battery)
Battery lifetime	Up to 12 years		
Nominal power	P_N	μW	30

INTERFACES - OVERVIEW

RAY	
Optical	ZVEI interface for communication, M-Bus protocol
M-Bus	According to EN 1434-3. Data reading and parametrization are via two wires with polarity reversal protection. (Meter is powered with energy via M-Bus Master)
Radio	868 MHz, real data or open metering protocol (not configurable, it's an own version)
Pulse	Output for heat meters or cooling meters (energy / volume), for cooling-heat meters (energy cooling / energy heating or energy cooling / total volume), for heat-cooling meters (energy heating / energy cooling or energy heating / total volume)

RADIO INTERFACE - SPECIFICATION

RAY		
Frequency	MHz	868.95
Protocol		Real data (according EN 13757) or open metering
Transmission power	mW	10
Transmission interval	sec.	64
Communication		BLUETOOTH OPTOHEAD and HYDRO-SET or IZAR@MOBILE

VOLUME- / ENERGY PULSE

RAY		
Output type		Open collector
Max. frequency	Hz	4
Max. input voltage	V	30
Max. input current	mA	100
Max. voltage drop at active output	V/mA	2/27
Max. current through inactive output	µA/V	5/30
Max. reverse voltage without destroying outputs	V	6
Min. pulse duration	ms	125
Min. pulse break	ms	125

RAY DN 15 - 20

COMPACT ENERGY METER | MECHANICAL

PRODUCT PICTURE



Standard M-Bus, Pulse



Radio

GENERAL

DN 15 - 20		
Temperature range	°C	5 ... 90
Ambient operating temperature	°C	0 ... 55
Ambient storage temperature	°C	-20 ... 55
Nominal pressure	PN bar	16
Mounting position		In any position, also overhead
Cable length of temperature sensor - installation in return pipe		1.5 m free / 0.4 m mounted in housing (forward sensor / return sensor)
Cable length of temperature sensor - installation in forward pipe		0.4 m mounted in housing / 1.5 m free (forward sensor / return sensor)
Approval		EN 1434 (22.52 / 00.02) / EC type examination certificate (DE-07-MI004-PTB030)
Dynamic range (q_p/q_i)	R	25 / 50 / 100

TECHNICAL DATA

Nominal diameter	DN	mm	15	15	20
Nominal flow rate	q_p	m^3/h	0.6	1.5	2.5
Overall length	L	mm	110	110	130
Maximum flow rate	q_s	m^3/h	1.2	3	5
Minimum flow rate	q_i	l/h	6*	15*	25*
Starting flow rate		l/h	1.5 - 2	3 - 4	5 - 6
Pressure loss at q_p	Δp	mbar	243	243	242
Flow rate at 0.1 bar pressure loss		m^3/h	0.385	0.962	1.607
Kvs value ($\Delta p=Q^2/Kvs^2$)			1.2	3.0	5.1

* at q_p/q_i 100

DIMENSIONS

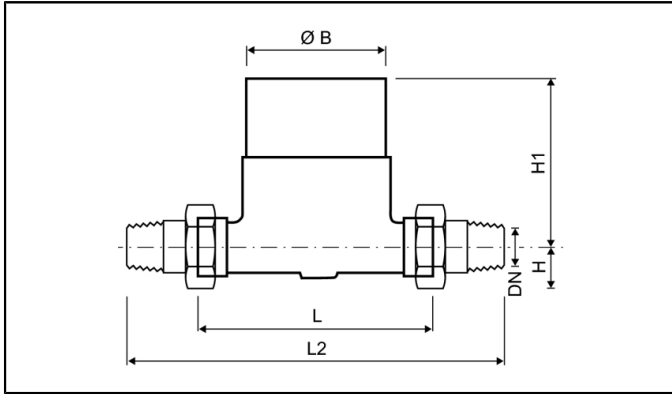

Nominal diameter	DN	mm	15	15	20
Nominal flow rate	q_p	m ³ /h	0.6	1.5	2.5
Overall length	L	mm	110	110	130
Overall length with coupling	L2	mm	190	190	210
Connection thread on meter		Inch	G $\frac{3}{4}$ B	G $\frac{3}{4}$ B	G1B
Connection thread of coupling		Inch	R $\frac{1}{2}$	R $\frac{1}{2}$	R $\frac{3}{4}$
Height	H	mm	20	20	20
Height	H1	mm	75	75	75
Diameter	$\varnothing B$	mm	63	63	63
Weight without coupling		kg	0.9	0.9	1

PRESSURE LOSS GRAPH / TYPICAL ERROR GRAPH

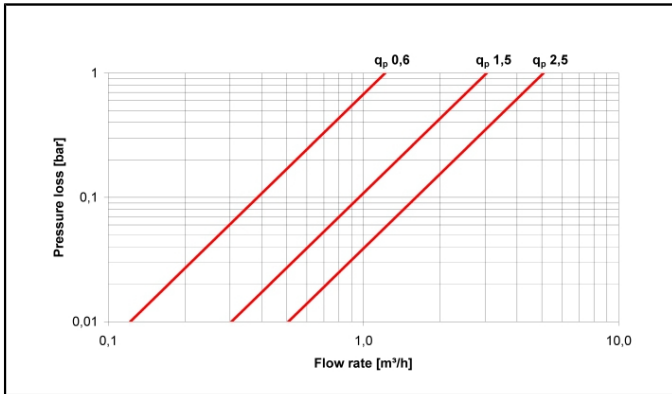

Pressure loss graph

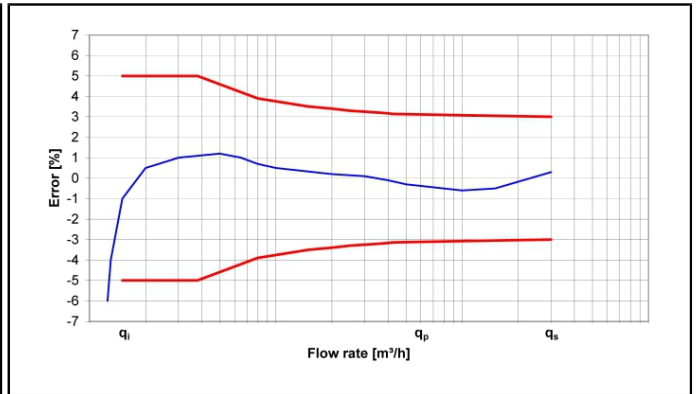

Typical error graph

RAY DN 25 - 40 | horizontal

COMPACT ENERGY METER | MECHANICAL

PRODUCT PICTURE



Standard M-Bus, Pulse



Radio

GENERAL

DN 25 - 40 horizontal		
Temperature range	°C	5 ... 90
Ambient operating temperature	°C	0 ... 55
Ambient storage temperature	°C	-20 ... 55
Nominal pressure	PN bar	16
Mounting position		Horizontal
Cable length of temperature sensor - installation in return pipe		6 m free / 1.5 m free (forward sensor / return sensor)
Cable length of temperature sensor - installation in forward pipe		1.5 m free / 6 m free (forward sensor / return sensor)
Approval		EN 1434 (22.52 / 06.02) / EC type examination certificate (DE-09-MI004-PTB001)
Dynamic range (q_p/q_i)	R	25 / 50 / 100 (with national approval 50)

TECHNICAL DATA

Nominal diameter	DN	mm	25	25	40
Nominal flow rate	q_p	m^3/h	3.5	6	10
Overall length	L	mm	260	260	300
Maximum flow rate	q_s	m^3/h	7	12	20
Minimum flow rate	q_i	l/h	35*	60*	100*
Starting flow rate		l/h	10	15	30
Pressure loss at q_p	Δp	mbar	170	240	200
Flow rate at 0.1 bar pressure loss		m^3/h	2.68	4.35	6.45
Kvs value ($\Delta p=Q^2/Kvs^2$)			8.5	13.7	20.4

* at q_p/q_i 100

RAY DN 25 - 40 | horizontal

COMPACT ENERGY METER | MECHANICAL

DIMENSIONS

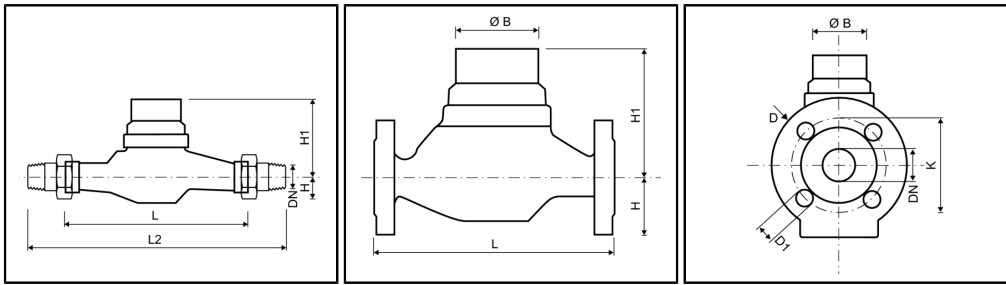

Nominal diameter	DN	mm	25	25	40
Nominal flow rate	q _p	m ³ /h	3.5	6	10
Overall length	L	mm	260	260	300
Diameter	Ø B	mm	63	63	63
DIMENSIONS - THREAD					
Overall length with coupling	L2	mm	378	378	438
Connection thread on meter		Inch	G1¼B	G1¼B	G2B
Connection thread of coupling		Inch	R1	R1	R1½
Height	H	mm	45	45	60
Height	H1	mm	110	110	115
Weight without coupling		kg	2.9	2.9	5.1
DIMENSIONS - FLANGE					
Flange diameter	D	mm	115	115	150
Hole circle diameter	K	mm	85	85	110
Number of screwholes		pcs	4	4	4
Screw hole diameter	D1	mm	18	18	18
Height	H	mm	52	52	70
Height	H1	mm	110	110	130
Weight with flanges		kg	4.9	4.9	8.6

PRESSURE LOSS GRAPH / TYPICAL ERROR GRAPH

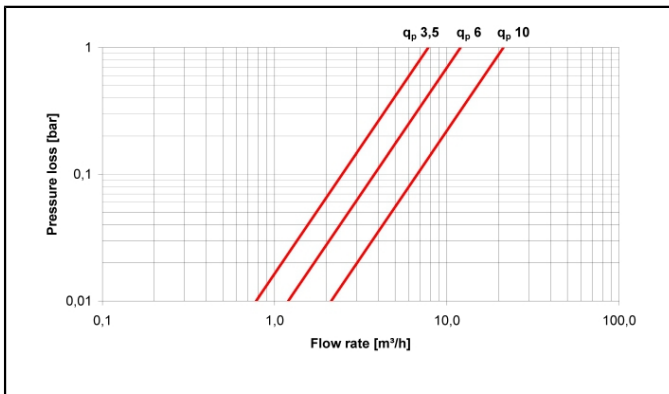

Pressure loss graph

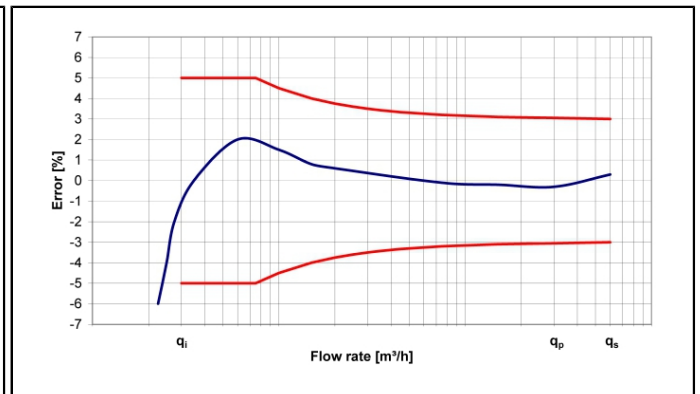

Typical error graph

RAY DN 25 - 40 | vertical

COMPACT ENERGY METER | MECHANICAL

PRODUCT PICTURE



Standard M-Bus, Pulse



Radio

GENERAL

DN 25 - 40 vertical		
Temperature range	°C	5 ... 90
Ambient operating temperature	°C	0 ... 55
Ambient storage temperature	°C	-20 ... 55
Nominal pressure	PN bar	16
Mounting position		Rising pipe, downpipe
Cable length of temperature sensor - installation in return pipe		6 m free / 1.5 m free (forward sensor / return sensor)
Cable length of temperature sensor - installation in forward pipe		1.5 m free / 6 m free (forward sensor / return sensor)
Approval		EN 1434 (22.52 / 06.02) / EC type examination certificate (DE-09-MI004-PTB001)
Dynamic range (q_p/q_i)	R	25 / 50 / 100 (with national approval 50)

TECHNICAL DATA

Nominal diameter	DN	mm	25	25	40
Nominal flow rate	q_p	m ³ /h	3.5	6	10
Overall length	L	mm	135 / 150	135 / 150	150 / 200
Maximum flow rate	q_s	m ³ /h	7	12	20
Minimum flow rate	q_i	l/h	35*	60*	100*
Starting flow rate		l/h	10	15	30
Pressure loss at q_p for installation in rising pipes		mbar	250	250	490
Pressure loss at q_p for installation in downpipes		mbar	250	250	250
Flow rate at 0.1 bar pressure loss - rising pipes		m ³ /h	2.21	3.79	4.52
Flow rate at 0.1 bar pressure loss - downpipes		m ³ /h	2.05	3.79	6.33
Kvs value ($\Delta p=Q^2/Kvs^2$)			6.5	12	20

* at q_p/q_i 100

DIMENSIONS

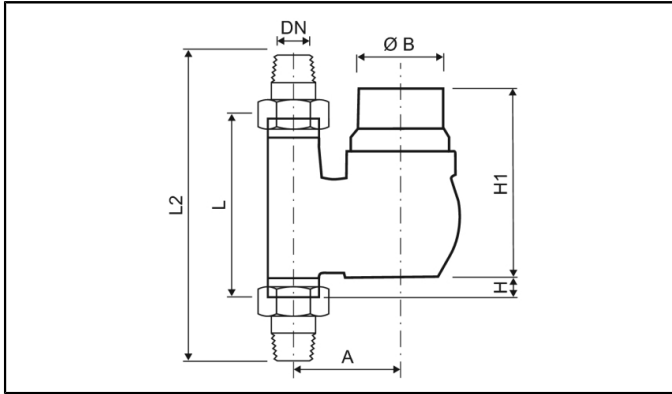

Nominal diameter	DN	mm	25	25	40
Nominal flow rate	q_p	m ³ /h	3.5	6	10
Overall length	L	mm	135 / 150	135 / 150	150 / 200
Overall length with coupling	L2	mm	253 / 268	253 / 268	338
Connection thread on meter		Inch	G1¼B	G1¼B	G2B
Connection thread of coupling		Inch	R1	R1	R1½
Height	H1	mm	161	161	191
Diameter	Ø B	mm	63	63	63
Width	A	mm	146	146	185
Weight without coupling		kg	3.1	3.1	5.5

PRESSURE LOSS GRAPH / TYPICAL ERROR GRAPH

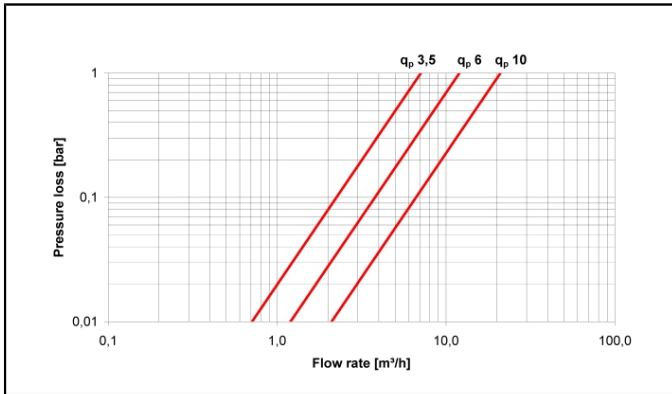

Pressure loss graph

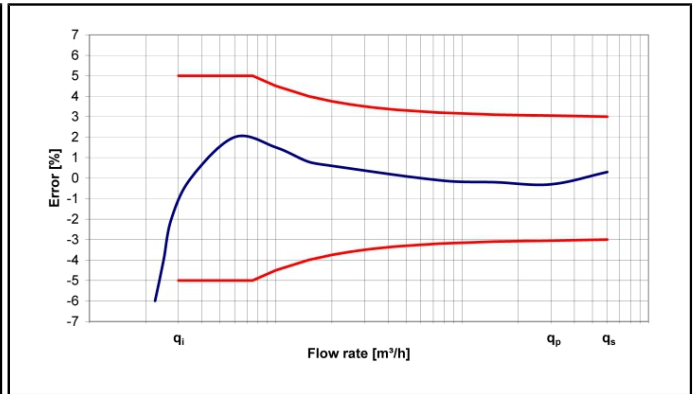

Typical error graph